

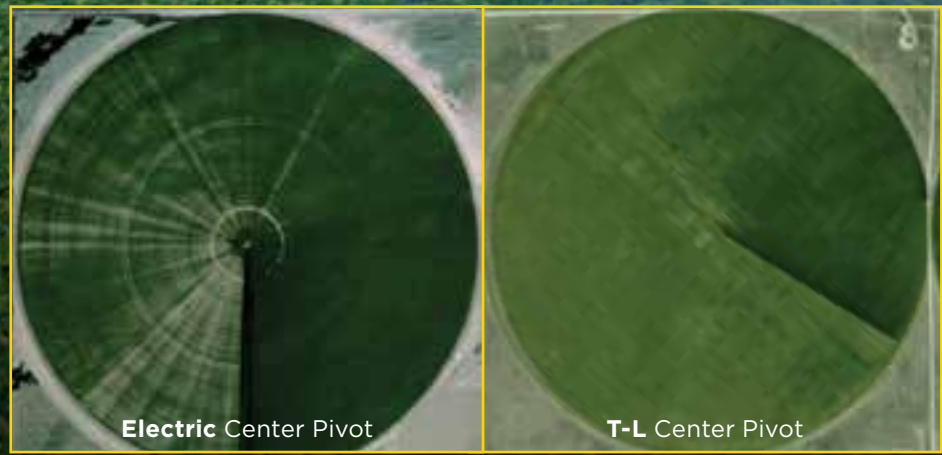

RECOVER YOUR LOST PRODUCTION WITH T-L.

Eliminate the "SPOKING" effect caused by the start-stop operation of electrically-powered pivot irrigation systems and get the benefits of even water distribution and maintenance cost savings



Corner Systems Quick Tow Systems 4 Wheel Towable Systems Linear Systems



HERE'S WHAT T-L OWNERS ARE SAYING...



There's No Time or Water to Waste

"Our three electric center pivot irrigation units will give me more trouble this year and take up more of my time than all 13 of our T-L units combined. I just know they will, because that has certainly been the case in the past."
- Darren and Garrett Stallwitz, Dumas, Texas



The Saving Grace in a Year of Drought

"Our ground has a lot of rolling terrain so we just liked the idea that the machines aren't stopping and starting every few feet."
- James and Jason Yarbrow, Dukedom, Tennessee



Keeping it Simple

"The bottom line is 'they run' and with very little maintenance, after 34 years, it just keeps going. It still has the original gearboxes and motors."
- LaMoine Smith, Minden, Nebraska



Surviving the Sands of Time

"The T-L machines have been in operation since 1980 and have accumulated at least 130,000 hours each. There is no doubt that T-L pivots are a quality brand and well-engineered."
- Jack King, Saudi Arabia



IRRIGATION PERFORMANCE LIKE NO OTHER.



"T-L | LIKE NO OTHER."

THE CHOICE IS SIMPLE.
www.tlirr.com



T-L is the manufacturer of hydraulically powered pivot irrigation systems that undergo thousands of hours of product research and testing for quality and performance. T-L's plant encompasses more than 40 acres, 18 buildings, plus a state-of-the-art galvanizing plant and tubing mill.



T-L Home Office at Hastings, NE Experience and Dedication Since 1955 Conventional Pivot Systems



THE CHOICE IS SIMPLE.
www.tlirr.com

151 East Hwy 6 & AB Road - P.O. Box 1047
Hastings, Nebraska 68902-1047 USA
Phone: 1-800-330-4264 · Fax: 1-800-330-4268
Phone: (402) 462-4128 · Fax: (402) 462-4617
sales@tlirr.com · www.tlirr.com





HYDROSTATICALLY POWERED FOR CONTINUOUS MOVEMENT... LIKE NO OTHER.

HYDROSTATIC DRIVE

T-L's hydrostatic drive offers many features not available on electric pivots. Unlike the stop-and-go action of electric models, each tower on a T-L system moves continuously. This is especially beneficial on low-pressure systems where uniform water application is critical for irrigation-applied fertilizer, herbicides and pesticides. Chances of a T-L tower getting stuck are reduced because of the improved traction that continuous movement provides on wet, rough terrain. A constant, smooth rate of travel also reduces wear on all drive components, while eliminating the wasteful power surge required to get a stopped tower moving again.

There is no wasted horsepower with a T-L because the power required to run the pump varies directly with the rotation time of the pivot. All T-L Irrigation Systems utilize environmentally friendly Hydroclear™ hydraulic fluid with an additive package specially designed to provide superior wear protection. The filtered hydraulic system assures long life.



Pivot point available with hydraulic swivel or wrap hoses. Inset photo shown with collector ring and strobe light.

POWER SOURCES | A T-L hydraulic pump can be powered by any convenient power source.



Belt Drive



Electric Motor
Single or 3-Phase



Engine

MANAGEMENT CONTROL OPTIONS



Manual Speed and Direction Control
Control speed and direction with two simple hydraulic valves.



T-L Point Control
Control speed and direction from the pivot or remote location. Safe 24VDC Control.



T-L Precision Point Control III
Control speed, direction, end gun, and auto/stop locations with GPS or encoder position sensors. Closed loop speed control for maximum uniformity. Safe 24VDC Control.



Precision Link
Works in combination with PPC III to manage your center pivot by any internet connected device. Pivot start/stop, direction, application rate and water pump control are a few features available. VRI (Variable Rate Irrigation) is also programmable with these features.



T-L Pivot Manager II
Create programs for full control of all irrigation functions. Monitor water pressure and flow. Closed loop speed control for maximum uniformity. Safe 24VDC Control.



Remote System Management
A GPS pivot control or monitoring system is available to remotely manage your T-L irrigation system. It can communicate through the internet to provide actual performance information and notification to a cell phone, smart phone, or computer, enabling timelier operating and water use decisions.

DRIVE SYSTEM OPTIONS

Choose from two types of hydrostatic drives: **worm or planetary**. Both provide the advantages of continuous movement and reliability, while the planetary option gives greater strength and efficiency.

T-L planetary and worm gear options are totally enclosed and coupled directly to the hydraulic motor eliminating the center gear drive, U-joints and other exposed moving parts found on electric pivot systems. Hydraulic motors and gear boxes are both easily accessible for maintenance.



Worm Gear Drive



Planetary Gear Drive

**CONTINUOUS MOVEMENT
MEANS EXTENDED GEAR LIFE**



SIMPLE AND RELIABLE ALIGNMENT CONTROL

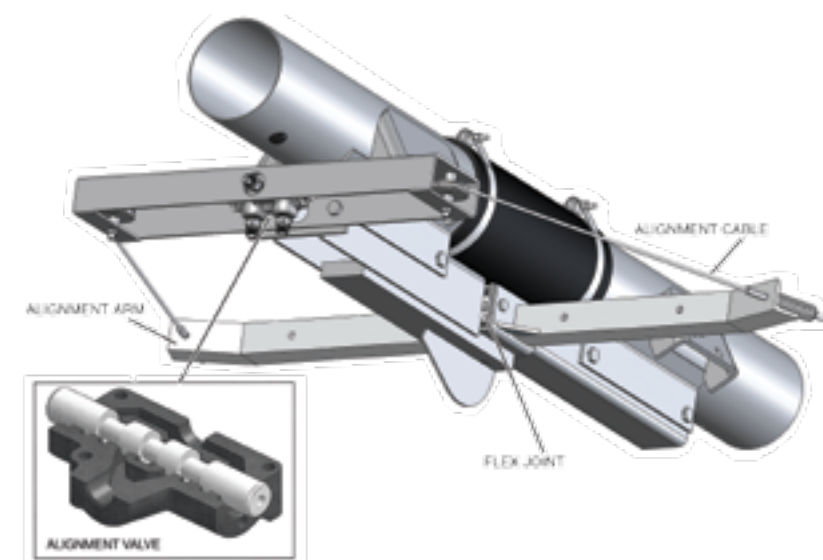

T-L systems maintain alignment through the use of a simple hydraulic spool valve. The alignment system moves the spool valve, metering the required hydraulic fluid flow for each tower maintaining continuous movement and alignment with the end tower. This simple hydrostatic control is vastly superior to the start-stop microswitch design used with single-speed electric motor drives.

Maintenance free, the valve spool is made of corrosion-resistant stainless steel. If a tower gets stuck or seriously misaligned, the valve will bypass hydraulic fluid through a return line to the pump, stopping the system and preventing major damage. Sensors shut down watering simultaneously with the system.

T-L System Structures are the best in the industry.



Tower Structure
T-L towers feature a heavy-duty pipe base and four vertical angle iron tower supports as a welded and dip-galvanized structure. Heavy-duty tower braces provide additional stability necessary for rugged terrain and furrowed conditions.



T-L Flex Joints
The T-L system features an extra tough external flex-joint, designed to withstand uneven and rolling terrain. The external flex-joint design assures a full flow of water with minimum pressure loss and turbulence.



Double Bolt Connection
Heavy-duty galvanized rods with truss tabs notched before welding allow for uniform stress on the truss rod connection. One bolt could hold the connection, but T-L uses two grade 5 bolts to reduce the shearing force on each bolt. It is another feature that keeps a T-L running trouble free ... longer.



T-L Owned Galvanizing Plant
The hot-dip galvanization protects all heavy-duty steel pipe, truss rods and tower structures. Our heavy-gauge mainline pipe is rolled into varying diameters for maximum water-flow, minimized friction loss and reduced pumping costs. Automatic drains at every tower empty the system after each use.

VALUE ADDED OPTIONS FROM T-L



Auto End Gun Booster
Reliable hydraulic powered end gun booster extends system coverage.



Automatic Reverse
Ideal for systems where field obstructions prevent a full 360° operation.



Position Stop
Stop your pivot at any degree of the circle with T-L's optional position stop.



Auto End Gun Shutoff
End gun shutoffs are hydraulically actuated for reliability with either hydraulic or electric pivot controls.

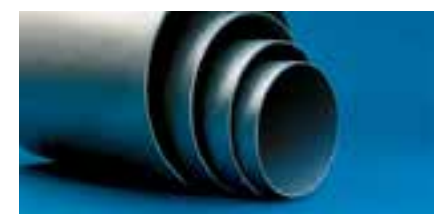

Pipe Materials and Sizes

- Galvanized: 5", 6 5/8", 8", and 10"
- Poly Coating for extending the system's pipe life in adverse water conditions. A T-L innovation. Available on all pipe sizes and pivot structures.
- Aluminum: 6" and 8"



Tire Options

- 11.2 x 24
- 16.9 x 24
- Recap
- 11.2 x 38
- 14.9 x 24

T-L Services



Pump & Power Division
T-L's Pump & Power Division provides quality water pumps and power units that are designed specifically for each pivot's application. Customers are assured their irrigation system is right for them and will produce the results expected. T-L is the only pivot manufacturer to offer this expertise with each sale.



Custom Sprinkler Designs
Choosing the right sprinkler package is critical to getting the best performance and water usage from the pivot system. T-L has its own sprinkler department that custom designs sprinkler systems for each pivot's application. Customers can be sure the system will fit their crop and soil conditions for optimum production.

